

Write your name here

Surname

Other names

**Pearson Edexcel**  
**International**  
**Advanced Level**

Centre Number

--	--	--	--	--

Candidate Number

--	--	--	--

# Mechanics M2

## Advanced/Advanced Subsidiary

Thursday 28 January 2016 – Morning  
**Time: 1 hour 30 minutes**

Paper Reference

**WME02/01**

**You must have:**

Mathematical Formulae and Statistical Tables (Blue)

Total Marks

--

**Candidates may use any calculator allowed by the regulations of the Joint Council for Qualifications. Calculators must not have the facility for symbolic algebra manipulation, differentiation and integration, or have retrievable mathematical formulae stored in them.**

### Instructions

- Use **black** ink or ball-point pen.
- If pencil is used for diagrams/sketches/graphs it must be dark (HB or B). Coloured pencils and highlighter pens must not be used.
- **Fill in the boxes** at the top of this page with your name, centre number and candidate number.
- Answer **all** questions and ensure that your answers to parts of questions are clearly labelled.
- Answer the questions in the spaces provided  
– *there may be more space than you need.*
- You should show sufficient working to make your methods clear. Answers without working may not gain full credit.
- Whenever a numerical value of  $g$  is required, take  $g = 9.8 \text{ m s}^{-2}$ , and give your answer to either two significant figures or three significant figures.
- When a calculator is used, the answer should be given to an appropriate degree of accuracy.

### Information

- The total mark for this paper is 75.
- The marks for **each** question are shown in brackets  
– *use this as a guide as to how much time to spend on each question.*

### Advice

- Read each question carefully before you start to answer it.
- Try to answer every question.
- Check your answers if you have time at the end.

Turn over ►

P46960RA

©2016 Pearson Education Ltd.

1/1/1/1/1/



P 4 6 9 6 0 R A 0 1 2 8

**PEARSON**









































6.

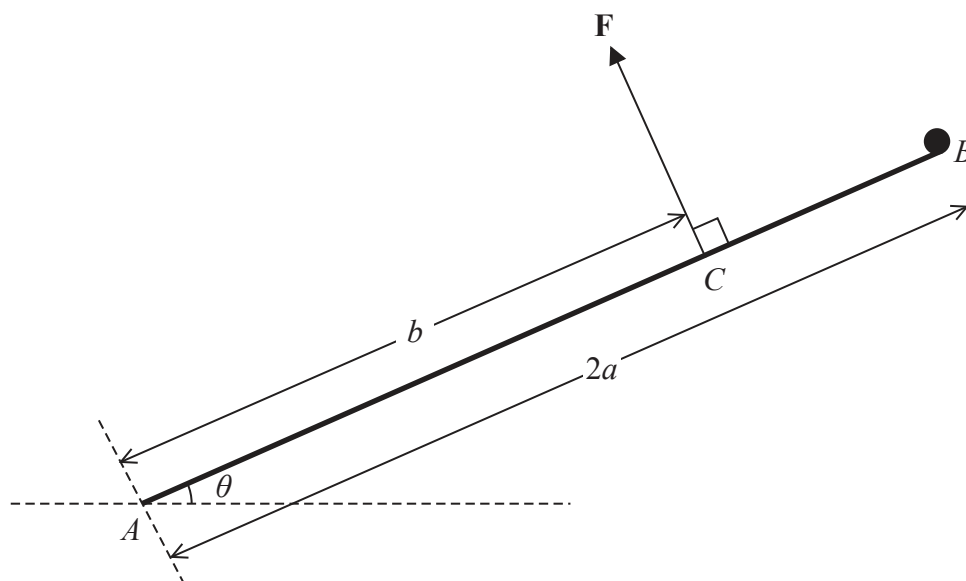

Figure 3

A uniform rod  $AB$ , of mass  $3m$  and length  $2a$ , is freely hinged at  $A$  to a fixed point on horizontal ground. A particle of mass  $m$  is attached to the rod at the end  $B$ . The system is held in equilibrium by a force  $\mathbf{F}$  acting at the point  $C$ , where  $AC = b$ . The rod makes an acute angle  $\theta$  with the ground, as shown in Figure 3. The line of action of  $\mathbf{F}$  is perpendicular to the rod and in the same vertical plane as the rod.

- (a) Show that the magnitude of  $\mathbf{F}$  is  $\frac{5mga}{b} \cos \theta$  (4)

The force exerted on the rod by the hinge at  $A$  is  $\mathbf{R}$ , which acts upwards at an angle  $\phi$  above the horizontal, where  $\phi > \theta$ .

- (b) Find
- (i) the component of  $\mathbf{R}$  parallel to the rod, in terms of  $m$ ,  $g$  and  $\theta$ ,
  - (ii) the component of  $\mathbf{R}$  perpendicular to the rod, in terms of  $a$ ,  $b$ ,  $m$ ,  $g$  and  $\theta$ . (5)
- (c) Hence, or otherwise, find the range of possible values of  $b$ , giving your answer in terms of  $a$ . (2)

---

---

---

---

---

---

---

---

---

---

DO NOT WRITE IN THIS AREA

DO NOT WRITE IN THIS AREA

DO NOT WRITE IN THIS AREA



















